

Figure 1

1. INTRODUCTION

This instruction sheet provides termination procedures for the unshielded 110Connect panel mount jacks (Category 3 and 5e) with universal wiring label.

NOTE All dimensions are in millimeters [with inches in brackets]. Figures are not drawn to scale.

Reasons for reissue of this sheet are provided in Section 4, REVISION SUMMARY.

2. DESCRIPTION

The jacks accept four pair, twisted-pair cable with 22 to 26 AWG solid conductors and 20 to 26 AWG stranded conductors. The maximum conductor insulation diameter is 1.27 mm [.050 in.].

3. TERMINATION

Strip back only as much cable jacket as necessary to perform termination. See Figure 2.

NOTE Generally, a strip length of 50.8 mm [2 in.] maximum will meet most applications, depending on method of termination.

NOTE Keep wire twist to within 12.7 mm [.50 in.] of termination.

NOTE Follow color code on label.

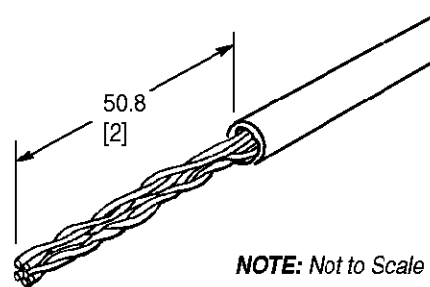

NOTE: Not to Scale

Figure 2

3.1. Option 1 (see Figure 3)

1. Lay conductors between connector blocks, aligning cable jacket with rear of jack assembly.
2. Lace brown pair and opposite rear color pair with appropriate color code slots (use minimum slack while maintaining twist to within 12.7 mm [.50 in.] of termination).

NOTE Wire termination requires the use of Impact Tool 558418-1, KRONE Universal Wire Insertion Tool, or stuffer cap.

CAUTION Set impact setting for low-impact. See Figure 3 for desired wire dress and cutoff orientation.

3. Use tool to punch wires down into slot and cut off excess wire. Remove loose wire pieces.
4. Repeat Steps 2 and 3 with blue pair and opposite front pair.
5. The optional stuffer cap may be used for termination or it may be added for additional strain relief.

3.2. Option 2 (For Additional Strain Relief) (see Figure 3)

1. Bend conductors back to right angle to cable and insert cable between connector blocks.
2. Pull brown pair and opposite rear color pair through opening on opposite sides. Bend wires around blocks and align them with appropriate color code slots (use minimum slack while maintaining twist).

NOTE Wire termination requires the use of Impact Tool 558418-1, KRONE Universal Wire Insertion Tool, or stuffer cap.

CAUTION Set impact setting for low-impact. See Figure 3 for desired wire dress and cutoff orientation.

3. Use tool to punch wires down into slot and cut off excess wire. Remove loose wire pieces.
4. Repeat Steps 2 and 3 with blue pair and opposite front pair.
5. Press conductors flat against blocks.

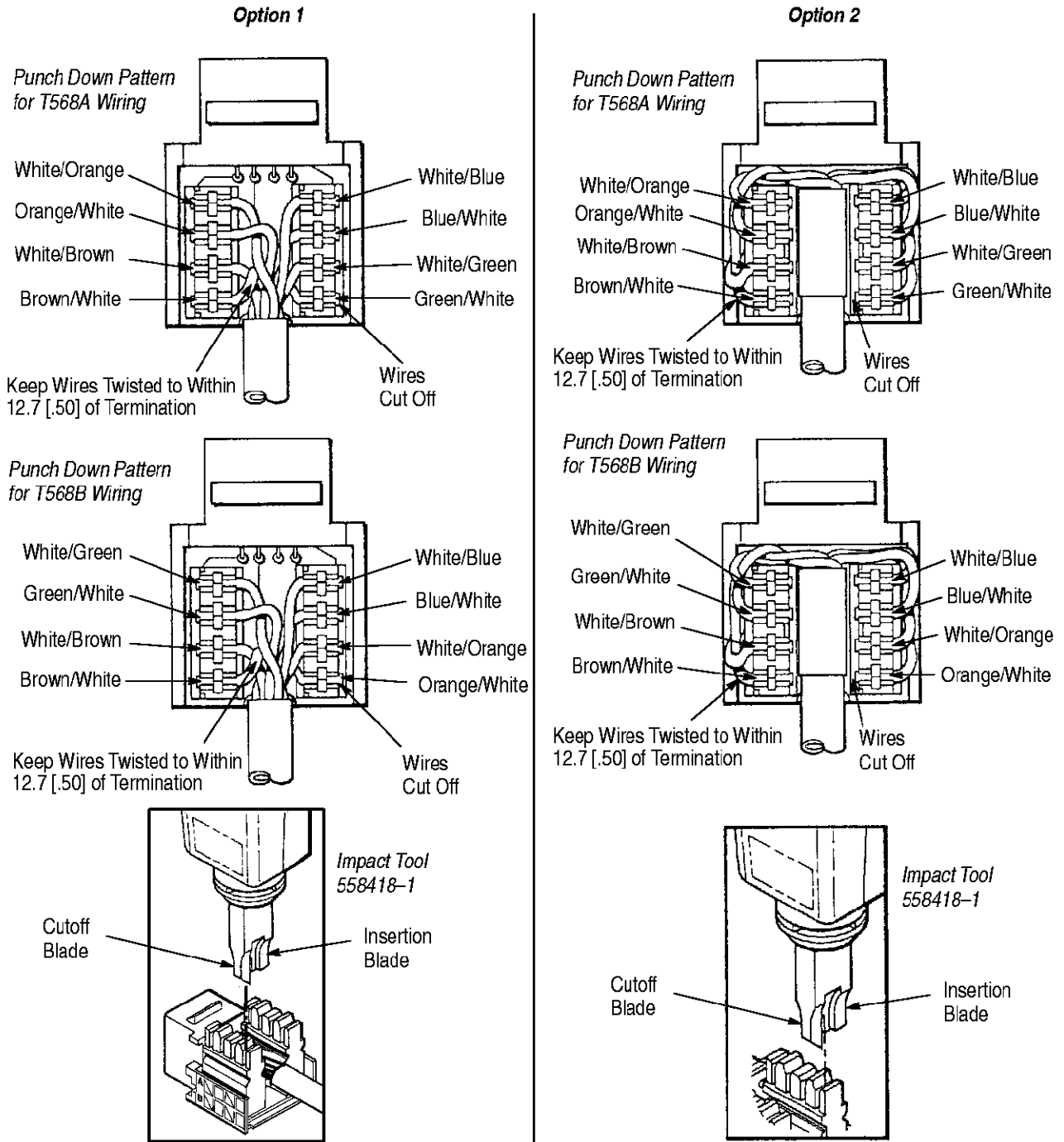

Figure 3

4. REVISION SUMMARY

Per EC 0990-0779-02:

- Removed caution regarding re-using components