

To obtain information on AMP NETCONNECT products, call PRODUCT INFORMATION at the number at the bottom of this page, or visit the AMP NETCONNECT website at www.ampnetconnect.com.

Figure 1

1. INTRODUCTION

This instruction sheet provides termination procedures for the SL Series 110Connect (Cat 3, Cat 5e, and Cat 6) modular jacks; the KL Series 110Connect (Cat 5e and Cat 6) modular jacks; and Secure SL Series 110Connect (Cat 6) modular jacks.

NOTE All dimensions are in millimeters [with inches in brackets]. Figures are not drawn to scale.

Reasons for reissue of this sheet are provided in Section 4, REVISION SUMMARY.

2. DESCRIPTION

The jacks accept four pair, twisted-pair cable with 22 through 24 AWG solid conductors and 24 AWG stranded conductors. The maximum conductor insulation diameter is 1.45 [.057].

3. TERMINATION

1. Strip back only as much cable jacket as necessary to perform termination. See Figure 2.

NOTE Generally, a strip length of 50.8 [2.00] maximum will meet the needs of most applications, depending on method of termination.

NOTE If using the optional bend-limiting strain relief, slide it over cable jacket as shown in Figure 2.

NOTE: Not to Scale

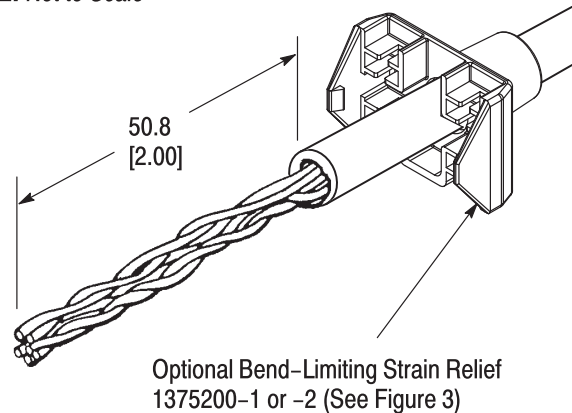

Figure 2

NOTE Keep wire pairs twisted to within 75 [3] of termination for Cat 3 jacks, or 12.7 [.50] for CAT 5e Jacks, or 6.0 [.24] for CAT 6 Jacks.

2. Align and lace a color-coded wire pair with the appropriate slots as indicated by the color coding on the wiring label (use minimum slack while maintaining twist, as indicated in Figure 3).

NOTE Wire termination requires the use of Impact Tool 558418-1 or SL Jack Termination Tools 1725150-1 or 1725150-2. Refer to 408-8858 for SL Jack Termination Tool instructions.

CAUTION Set impact setting for low-impact. Orient tool so cutoff blade is on outside of block and vertical.

3. Use tool to punch wires down into slot and cut off excess wire. Remove loose wire pieces.

4. Repeat Steps 2 and 3 with all wire pairs.

5. Slide bend-limiting strain relief (if used) onto jack. Latches on strain relief will engage tabs on rear of jack as indicated in Figure 3.

4. REVISION SUMMARY

- Added KL, and Secure SL Series 110Connect Jacks
- Updated format to current corporate requirements

Four-Pair Color-Coded Universal Wiring Label

Three-Pair Color-Coded Wiring Label

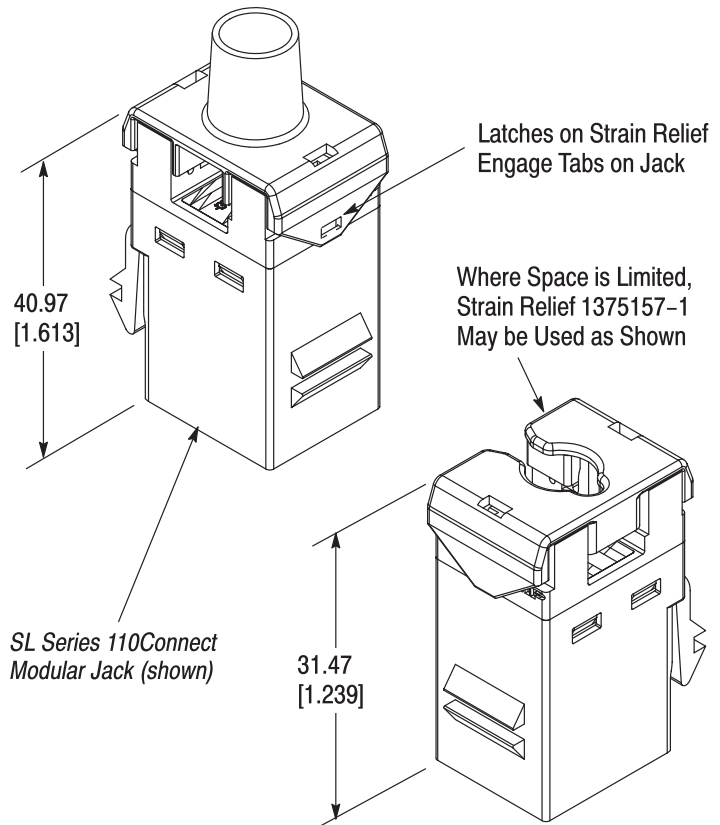
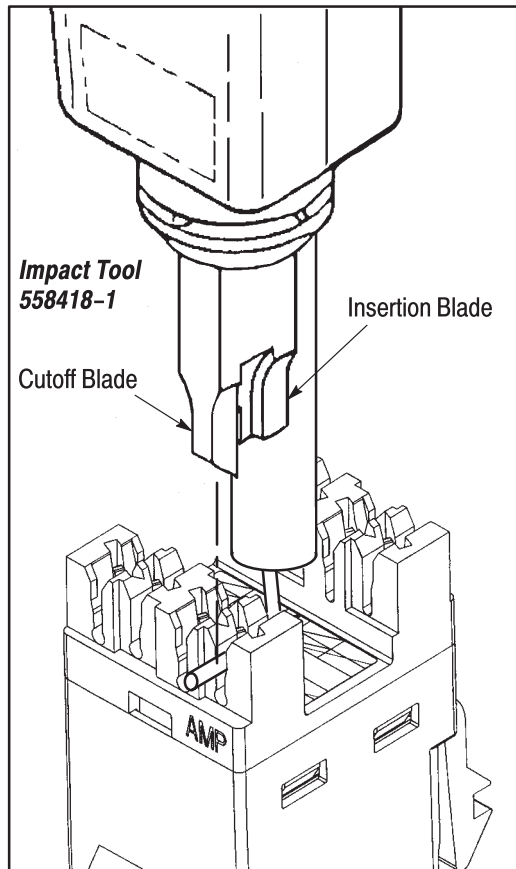
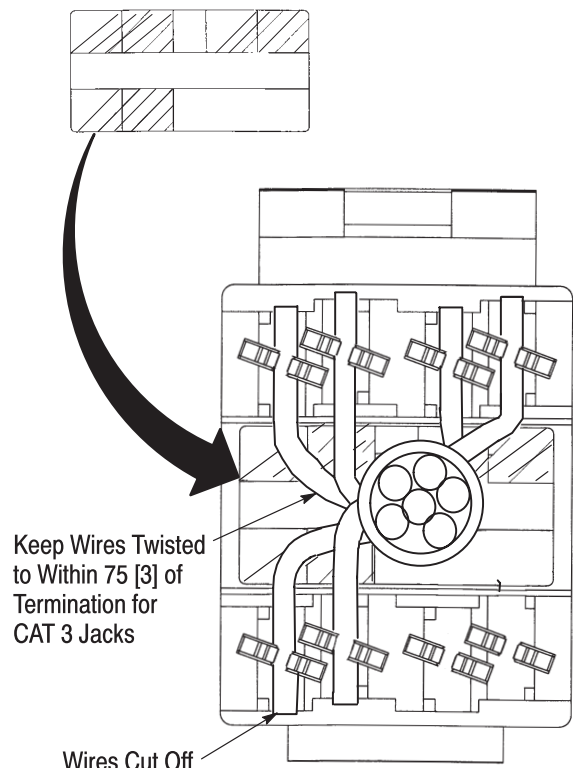
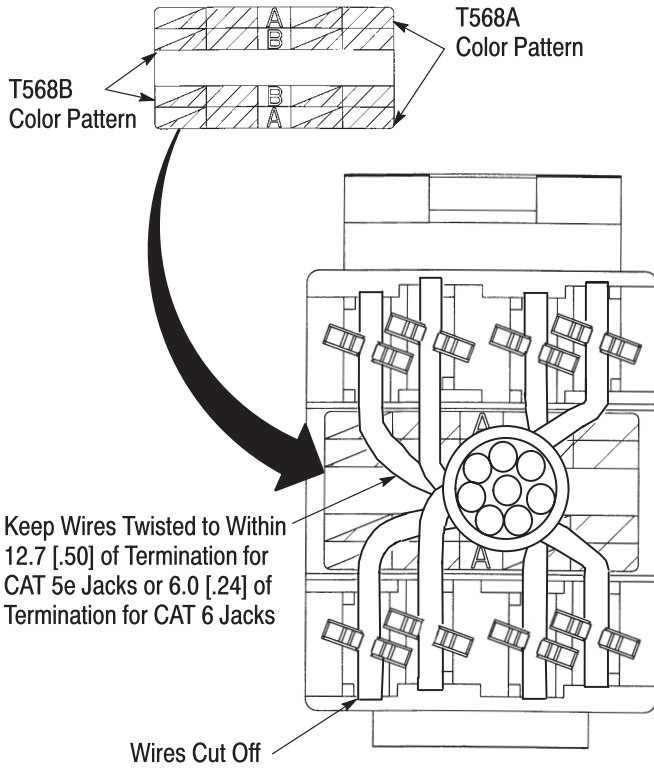

Figure 3